

The background of the slide is a photograph of a large industrial turbine. The turbine is a massive, cylindrical structure with a highly reflective, metallic surface. It is situated in a large, industrial-looking room with other machinery and pipes visible in the background. The lighting is somewhat dim, highlighting the texture and curvature of the turbine.

L4 – Medium and low head generating units

Dr. Elena Vagnoni
elena.vagnoni@epfl.ch

Topics of the lecture

Francis, Kaplan and Bulb turbines:

- Classification and geometrical proprieties
- Operating Principle
- Special Issues
- Real world examples

From L2: Classification of Hydraulic

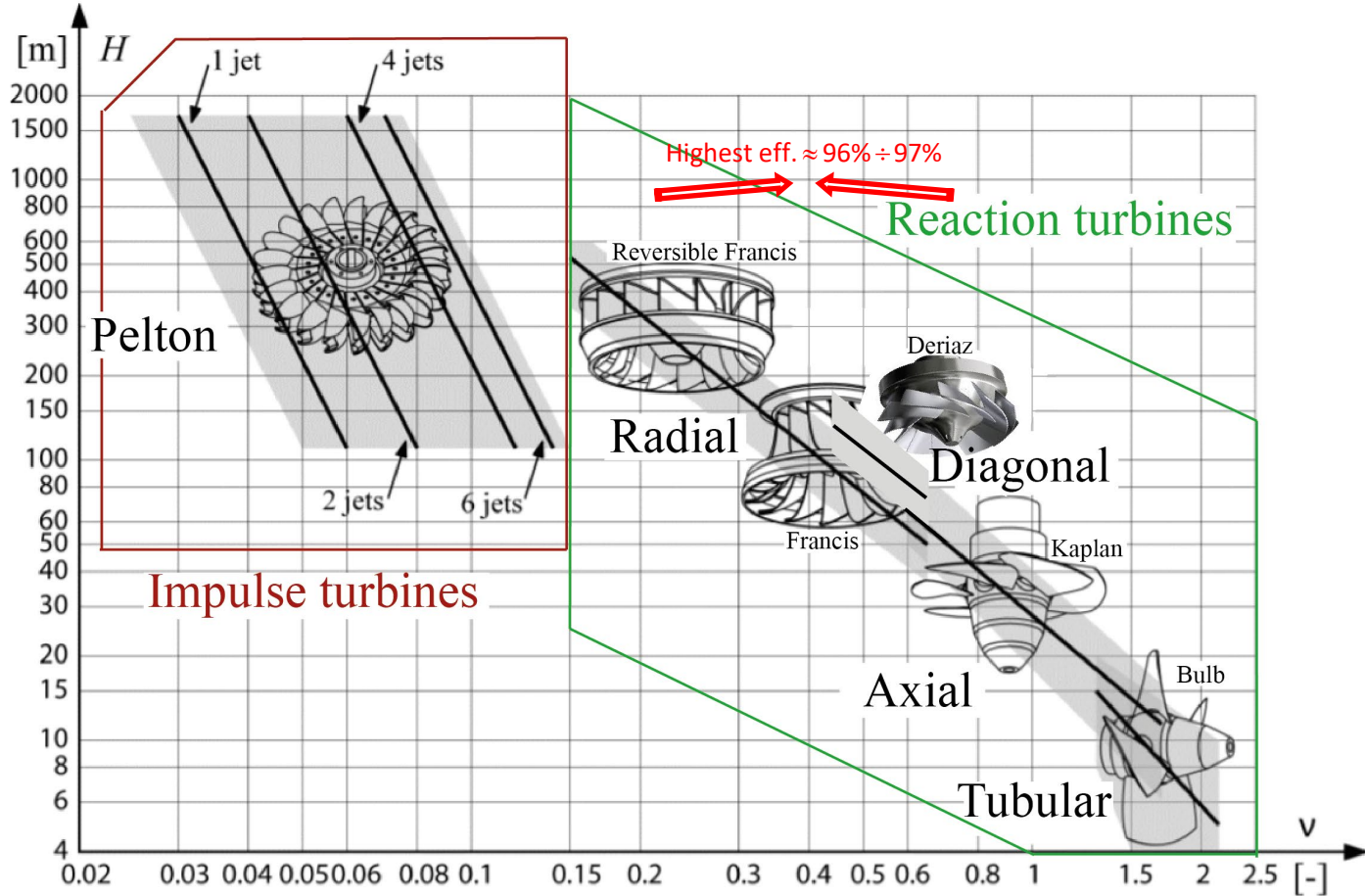

Head = H (m)
 Discharge = Q ($\text{m}^3 \cdot \text{s}^{-1}$)
 Speed = N (min^{-1})

$$v = 2^{\frac{1}{4}} \pi^{\frac{1}{2}} \times n \times \frac{Q^{\frac{1}{2}}}{E^{\frac{4}{3}}}$$

Classification of Hydraulic Runners

Francis Runners

- Reaction machine
- Radial flow
- Medium Head

Low specific speed

$$\begin{aligned} n_q &= 12 \dots 35 \\ v &= 0.10 \dots 0.22 \\ \eta_{QE} &= 0.04 \dots 0.10 \end{aligned}$$

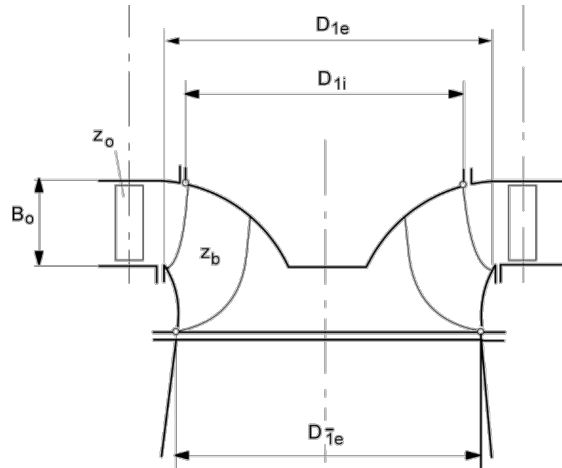
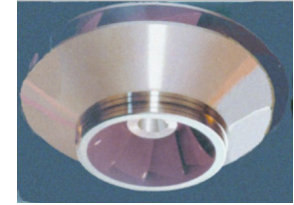
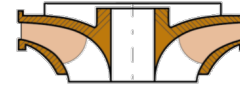

High specific speed

$$\begin{aligned} n_q &= 35 \dots 80 \\ v &= 0.22 \dots 0.50 \\ \eta_{QE} &= 0.10 \dots 0.24 \end{aligned}$$

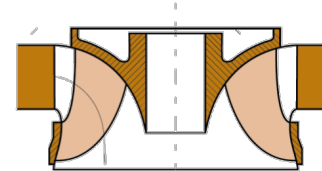

Classification and geometrical proprieties

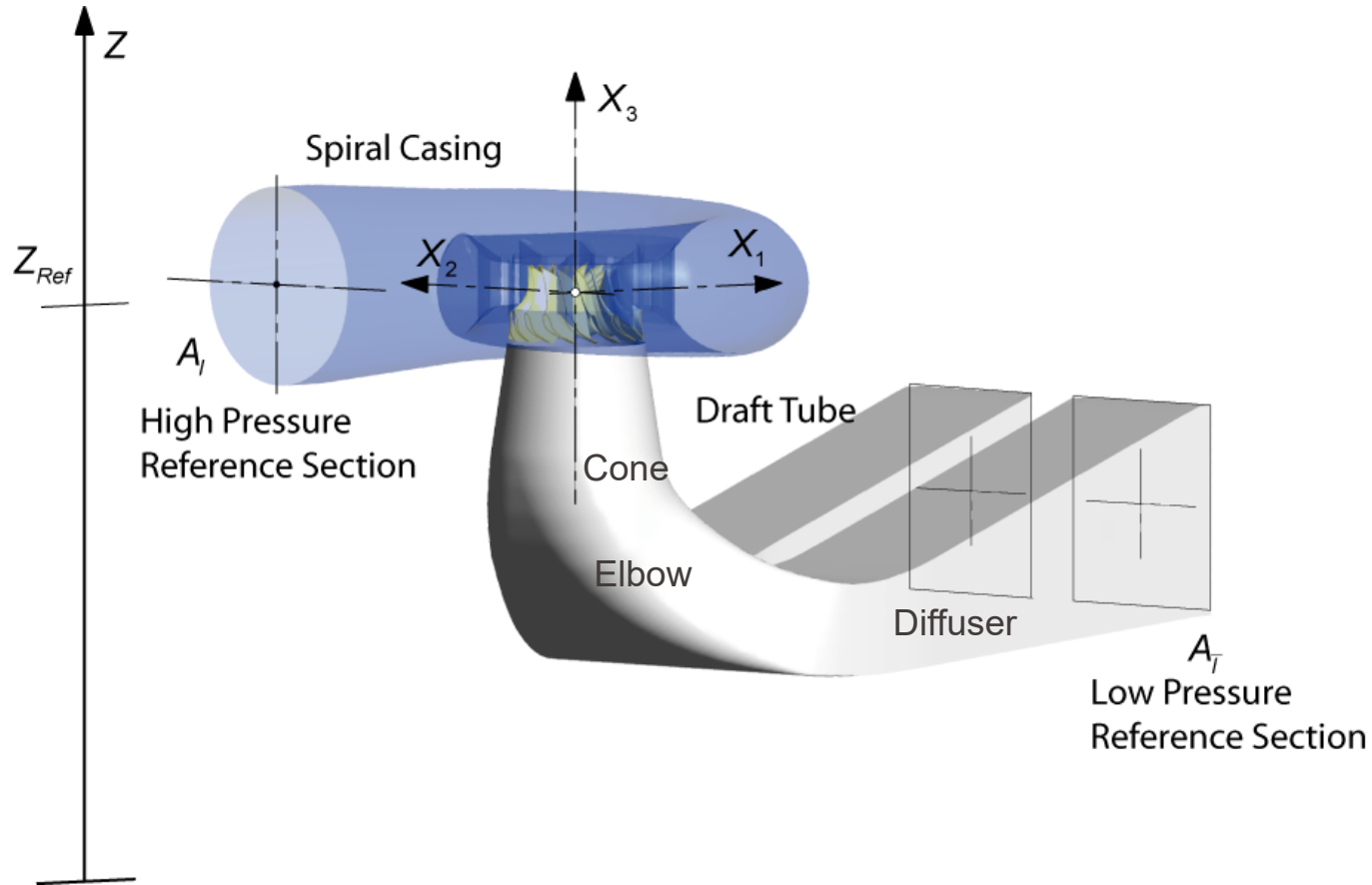

Classification and geometrical proprieties

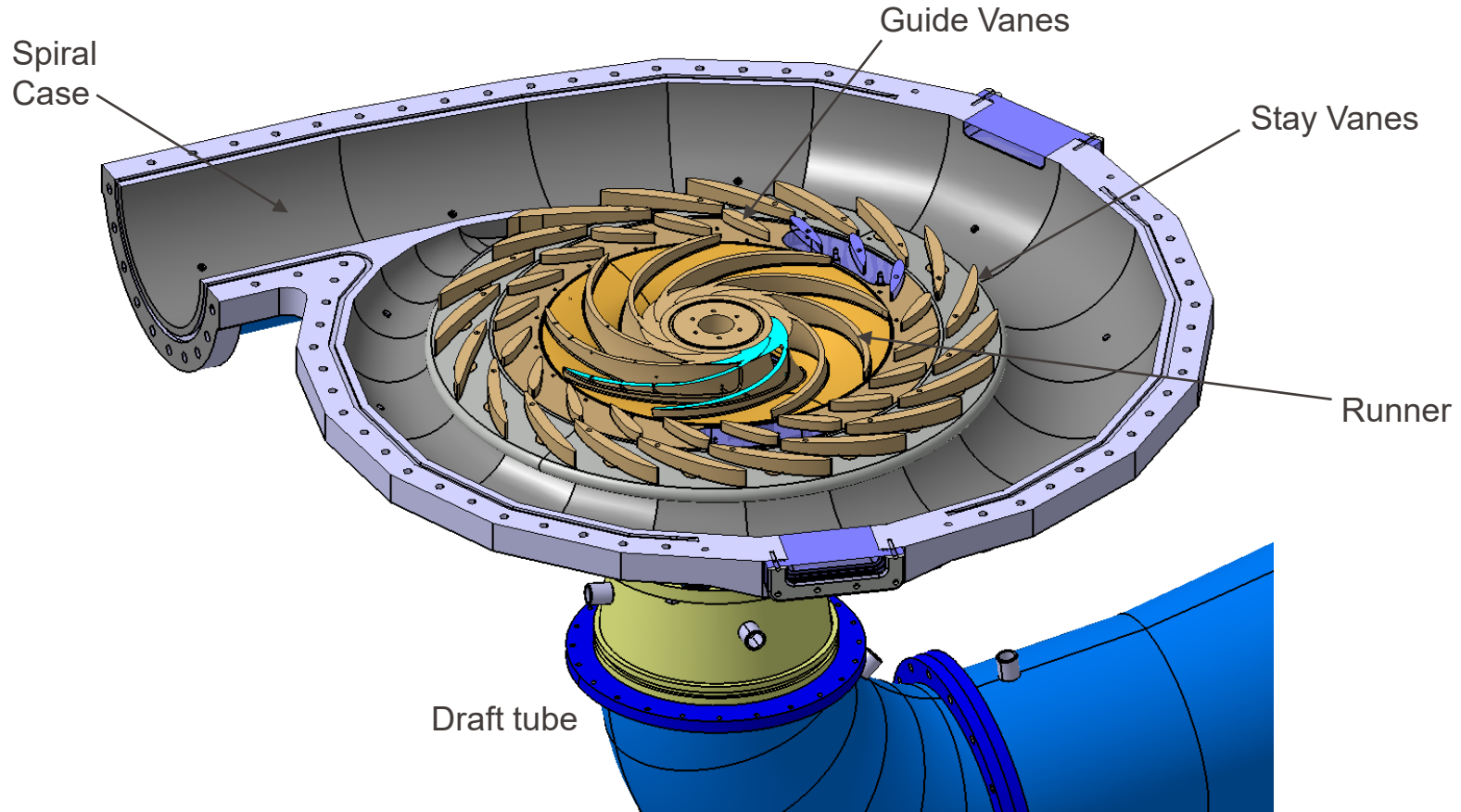

Classification and geometrical proprieties

Rotating Frame

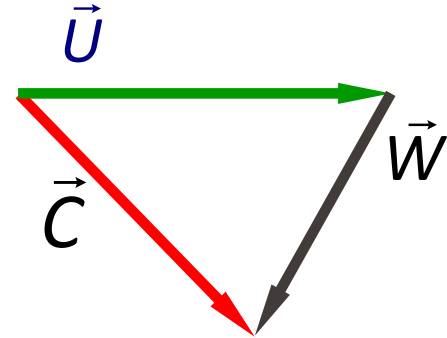
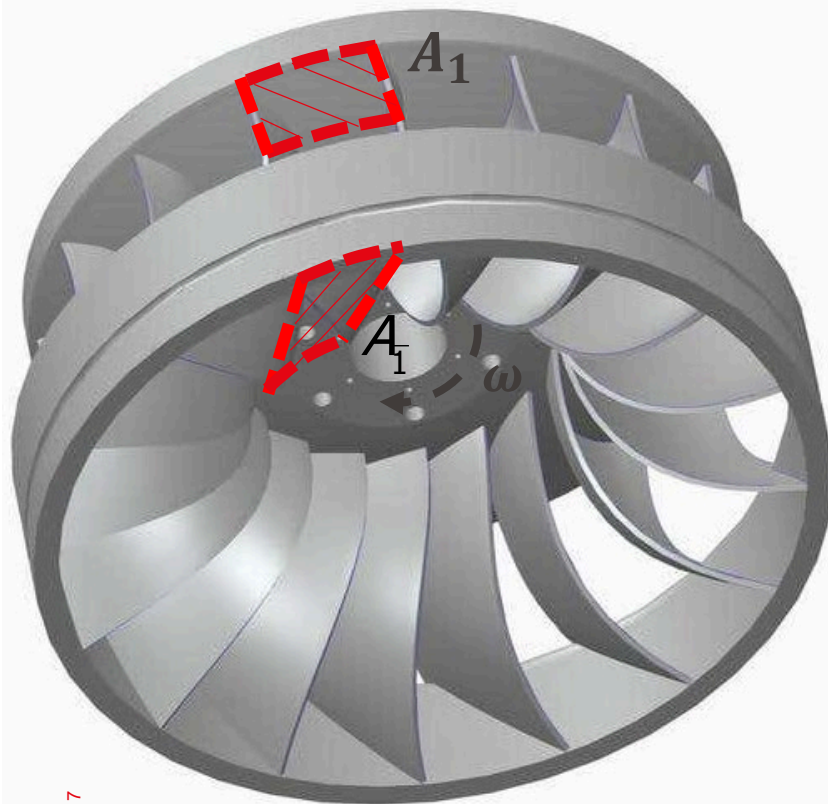

- Absolute Flow Velocity

$$\vec{C} = \vec{U} + \vec{W}$$

- Rotating Velocity $\vec{U} = \vec{\omega} \times \vec{X}$
 $= \omega R$

- Relative Flow Velocity

$$\vec{W} = \vec{C} - \vec{U}$$

Classification and geometrical proprieties

Blade Shape

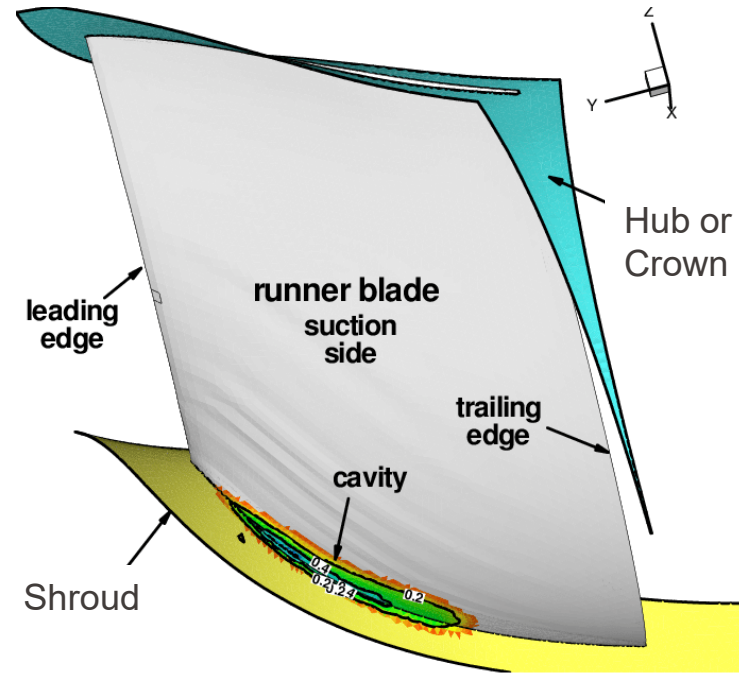
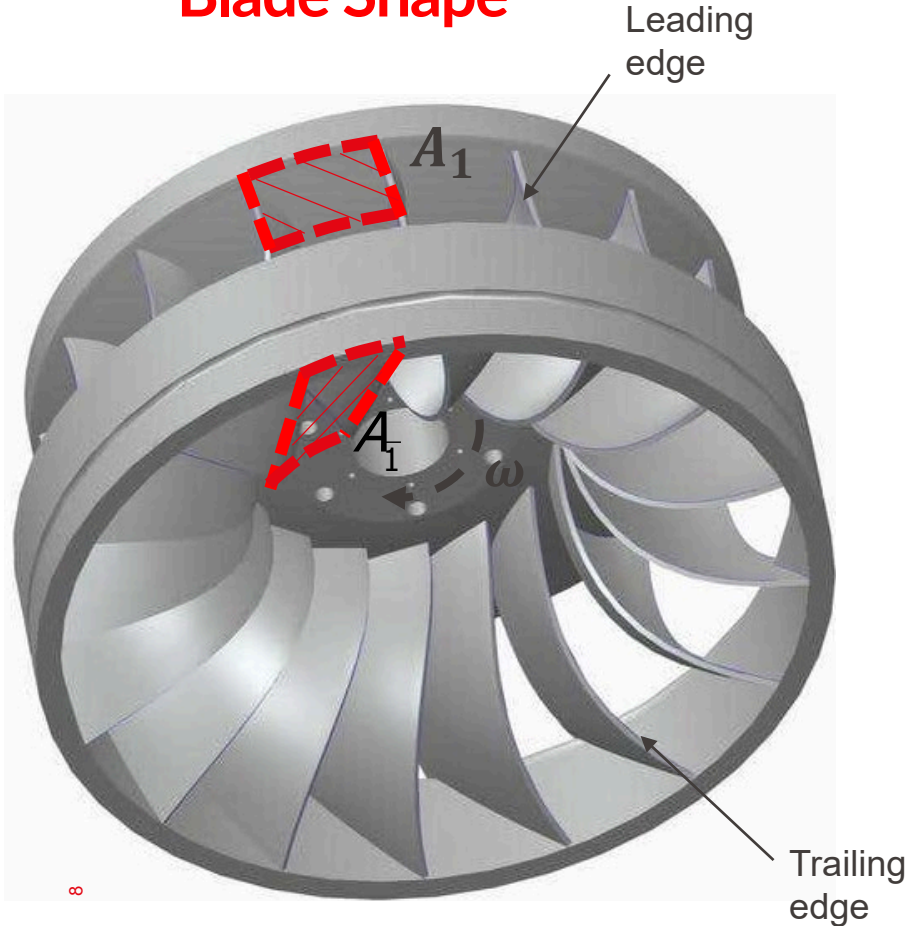

Classification and geometrical proprieties

Blade to Blade view

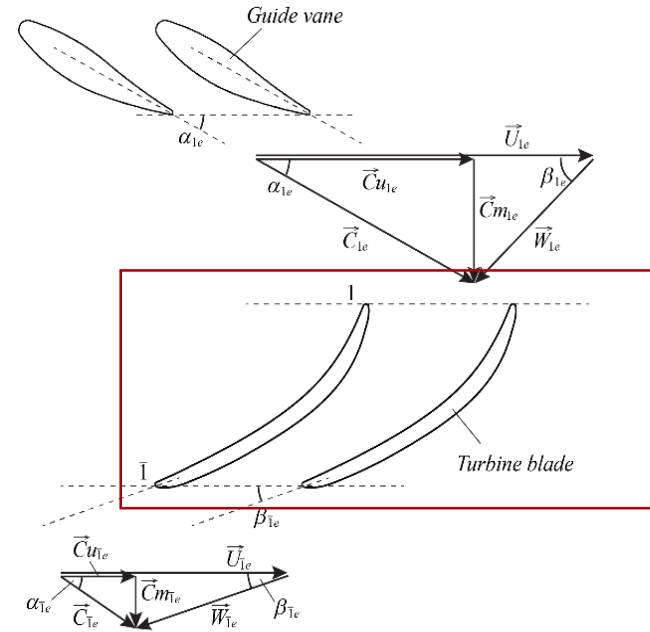
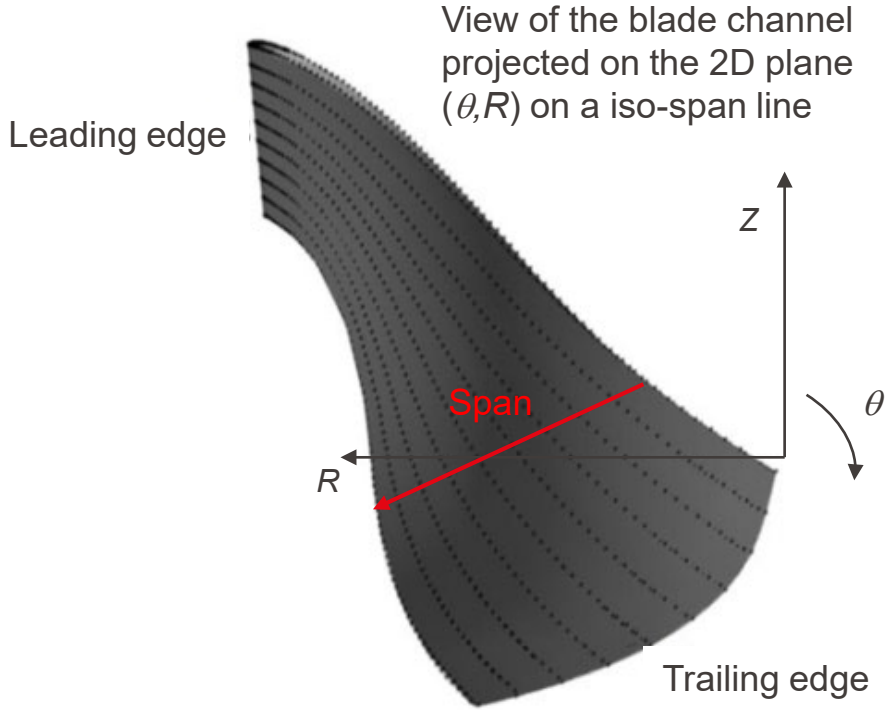

- Meridional Component $Cm = \frac{Q}{A}$
- Tangential Component $Cu = \frac{Cm}{tg\alpha} = U - \frac{Cm}{tg\beta}$

Classification and geometrical proprieties

Meridional view

View of the blade projected on the 2D plane (Z,R)

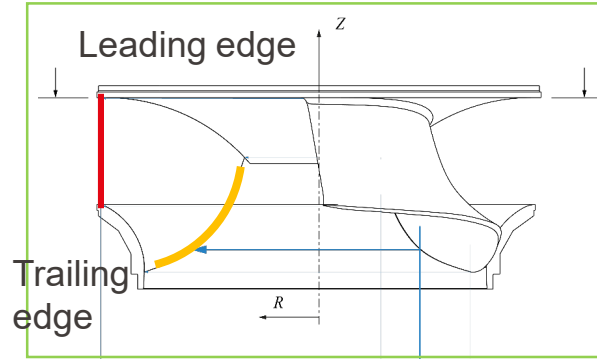
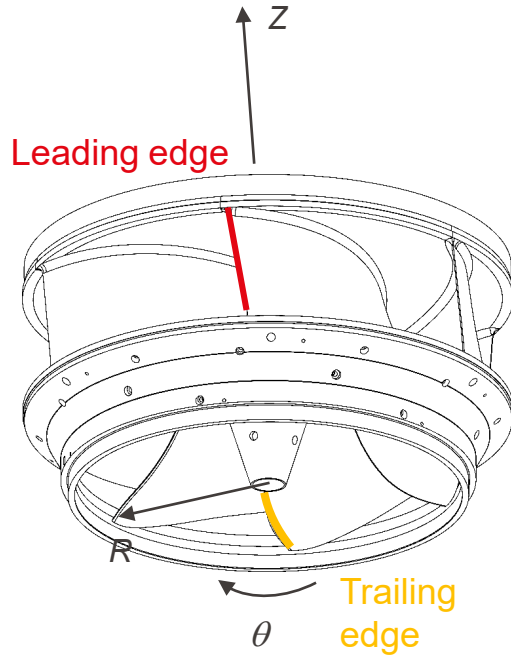

Meridional view

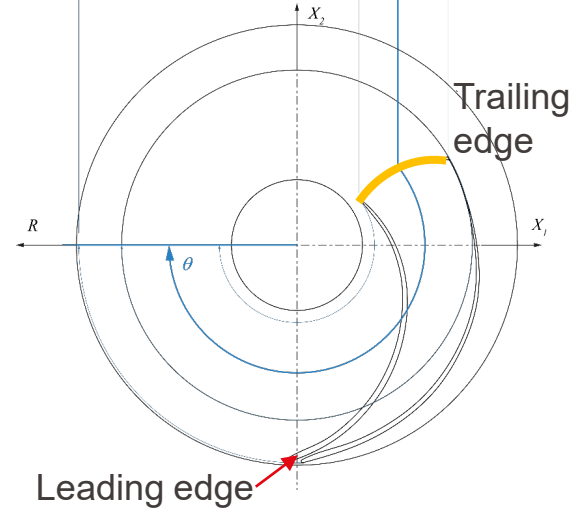

Classification and geometrical proprieties

Meridional view

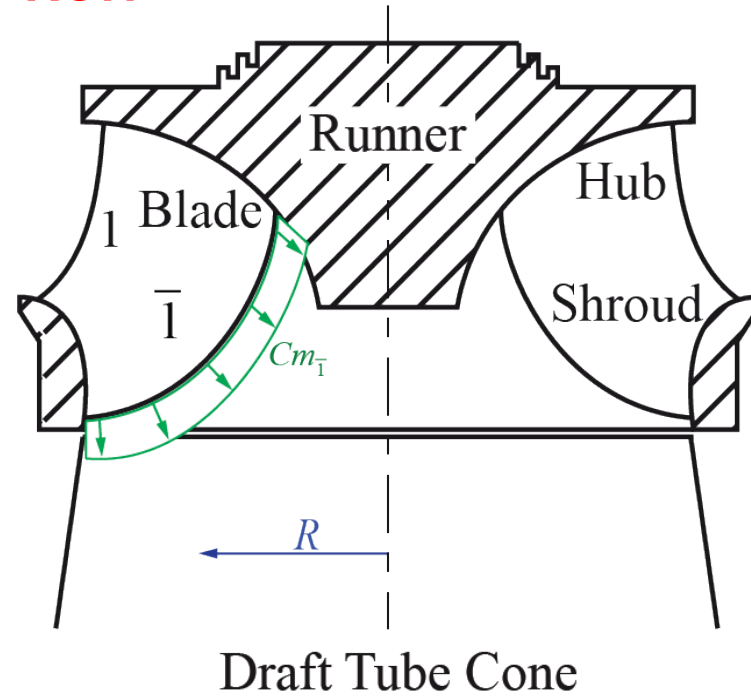

From L2: Classification of Hydraulic Runners

Runner/impeller specific energy transfer

- Transferred Specific Energy

$$gH_1 - gH_{\bar{1}} = E_t \pm E_{rb} \quad (\text{J} \cdot \text{kg}^{-1})$$

- Specific Energy

$$gH = \frac{p}{\rho} + gZ + \frac{C^2}{2} \quad (\text{J} \cdot \text{kg}^{-1})$$

- Specific Energy Balance:

$$E_t = \underbrace{\left(\frac{p_1}{\rho} - \frac{p_{\bar{1}}}{\rho} \right)}_{\text{Displacement}} + \underbrace{\left(\frac{C_1^2}{2} - \frac{C_{\bar{1}}^2}{2} \right)}_{\text{Impulse}} + \underbrace{[gZ_1 - gZ_{\bar{1}}]}_{\text{Water Wheel}} \pm \underbrace{E_{rb}}_{\text{Loss}} \quad (\text{J} \cdot \text{kg}^{-1})$$

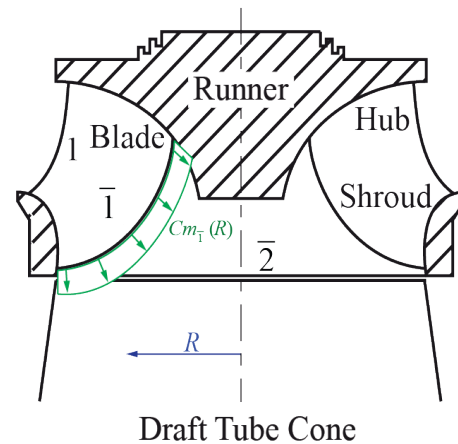

Operational Properties

The Global Euler Equation

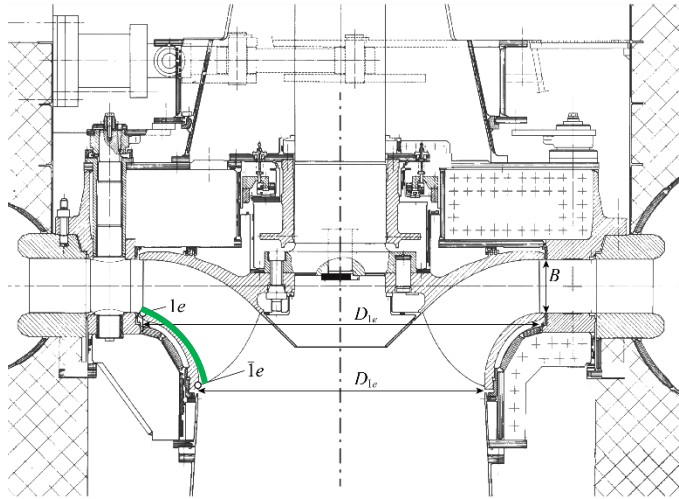

1D Equation: local form of the transferred energy by considering any particular streamline, for example, the transferred specific energy is defined by using the outer, external, streamline between the 2 points:

$$E_t = k_{C_{u1e}} \vec{C}_{1e} \cdot \vec{U}_{1e} - k_{C_{u\bar{1}e}} \vec{C}_{\bar{1}e} \cdot \vec{U}_{\bar{1}e}$$

- As the Euler equation is defined for the mean flow, the local form uses the following flow velocity distribution coefficients to take into account the influence of the spatial velocity distribution :

$$k_{c_{ux}} = \left| \frac{\int (\vec{C} \cdot \vec{U}) \vec{C} \cdot \vec{n} dA}{Q_t (\vec{C}_x \cdot \vec{U}_x)} \right|$$

- Turbine Flow: Uniform Inlet & Solid Body Rotation Outlet.

Operational Properties

The Global Euler Equation

Uniform flow at turbine inlet

$$k_{C_{uA_{1e}}} = \left| \frac{\int_{A_{1e}} (\vec{C} \cdot \vec{U}) \vec{C} \cdot \vec{n} dA}{Q_t (\vec{C}_{1e} \cdot \vec{U}_{1e})} \right| = 1$$

$$k_{C_{mA_{1e}}} = \left| \frac{\int_{A_{1e}} \vec{C} \cdot \vec{n} dA}{A_{1e} C_{m_{1e}}} \right| = 1$$

Operational Properties

Velocity triangles for Francis runners

~~$$E_t = U_{1e} C_{u_{1e}} - k_{C_{u_{1e}}} U_{1e} C_{u_{1e}}$$~~

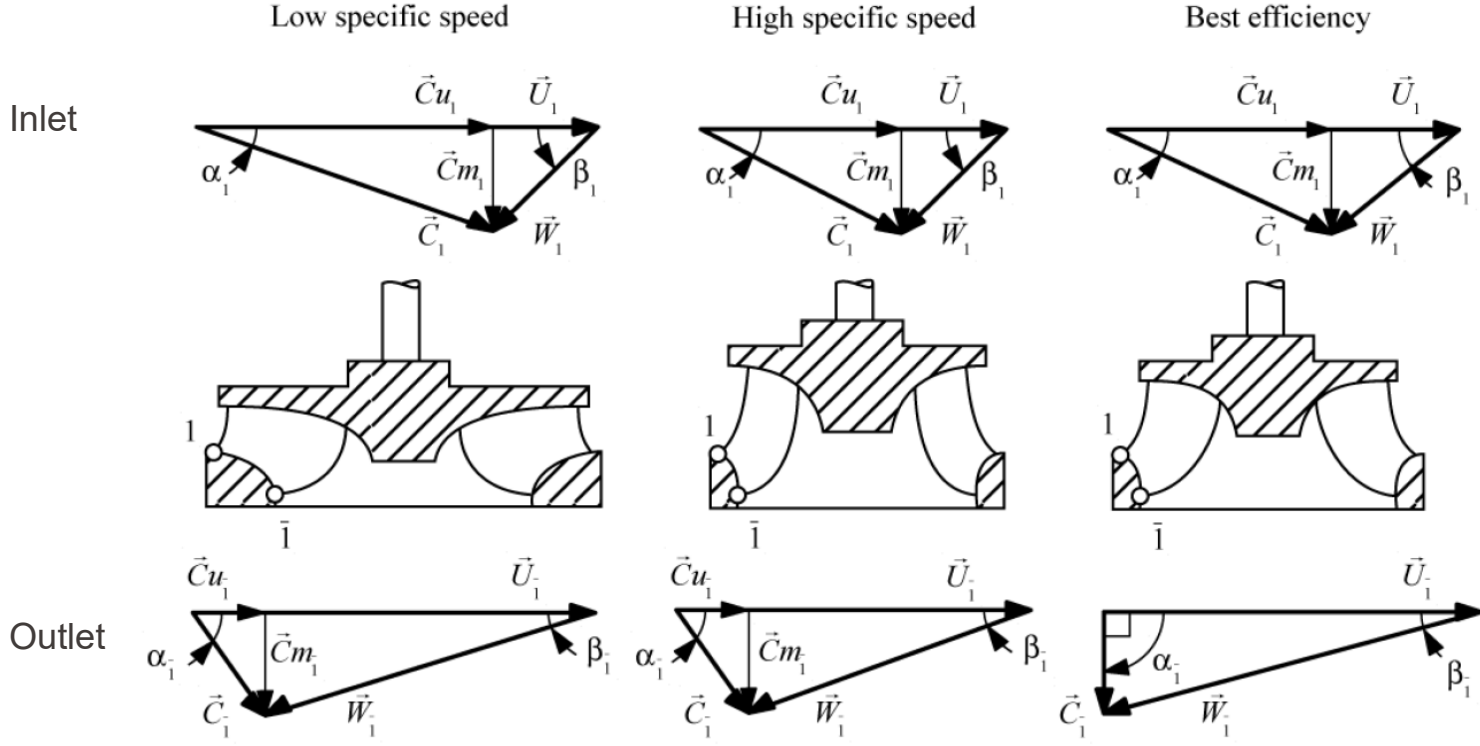

Axial outlet flow
 $C_{u_{1e}} = 0$

Operating issues

Performance degradation

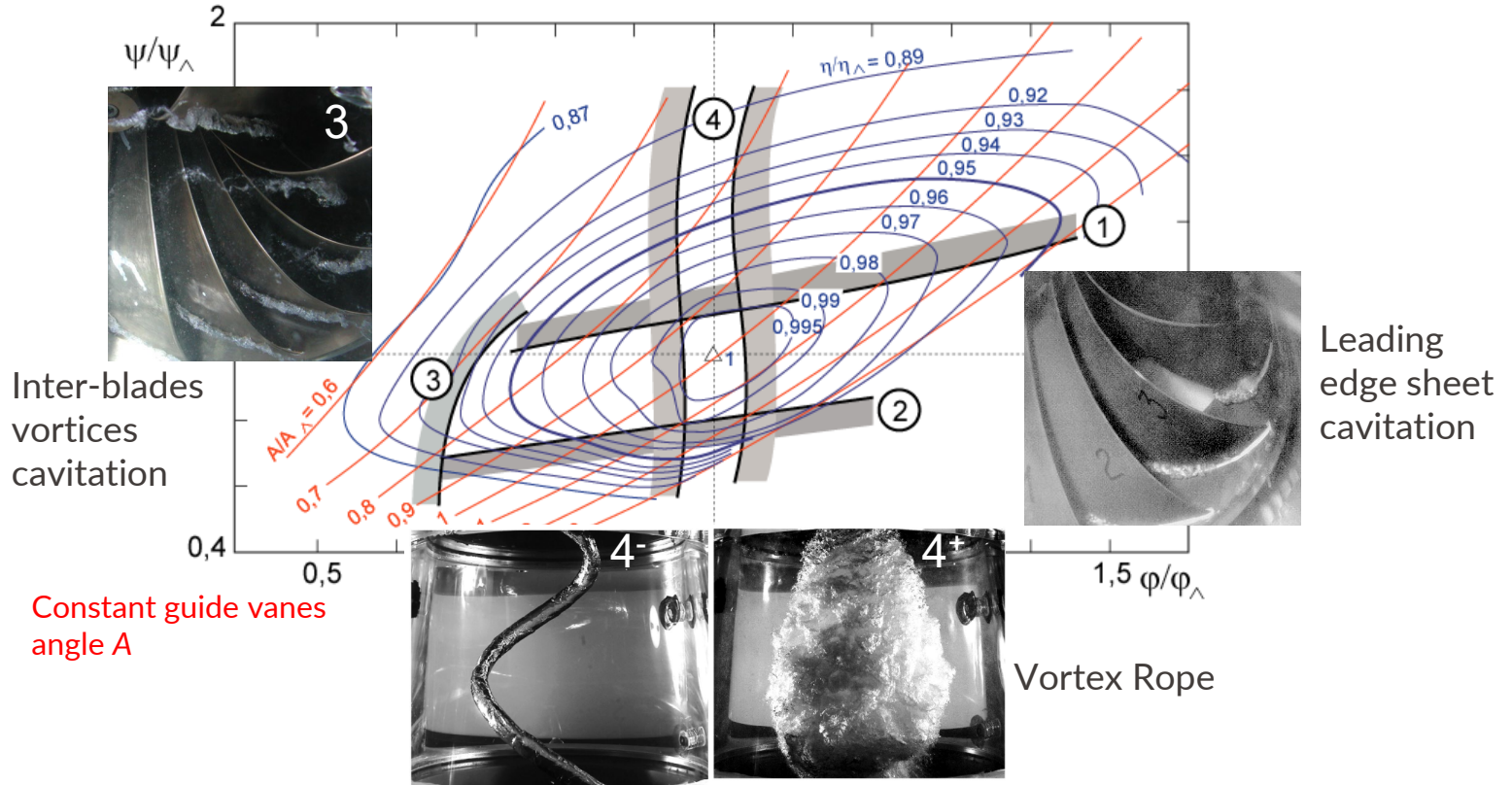

EPFL From L2: Classification of Hydraulic Runners

Machine setting level

Nomenclature:

- η (-) Efficiency
- σ_i (-) Inception: 1st Cavity !
- σ_{pl} (-) Plant Value
- σ^* (-) 1st Efficiency Change
- σ_1 (-) 1% Efficiency Drop

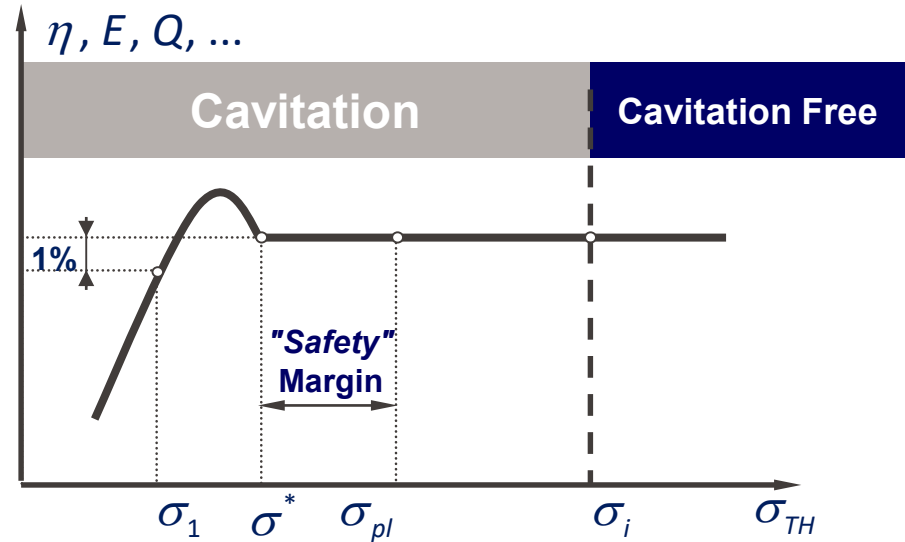

Operating issues

Unsteady Flow in Francis Draft Tube

Precession vortex rope



Axisymmetric vortex rope

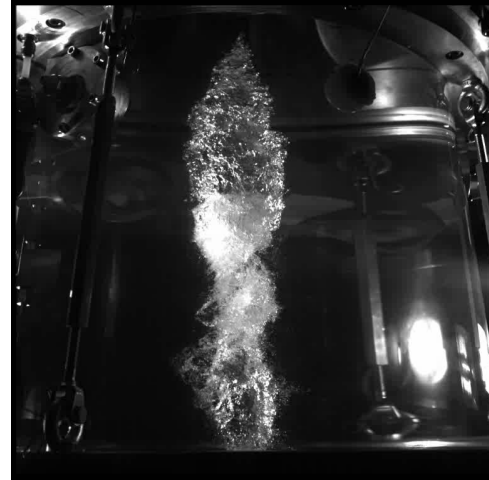

Partial Load: $Q < Q_{BEP}$

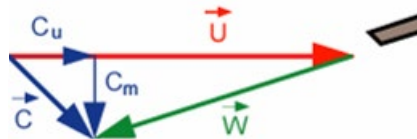

Velocity Triangle at
the runner outlet

Full Load: $Q > Q_{BEP}$

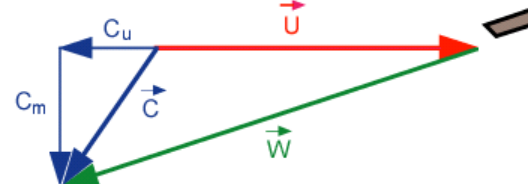

Driving Parameters Discharge and Thoma number

Operating issues

Pressure fluctuations \rightarrow Power surge and vibrations

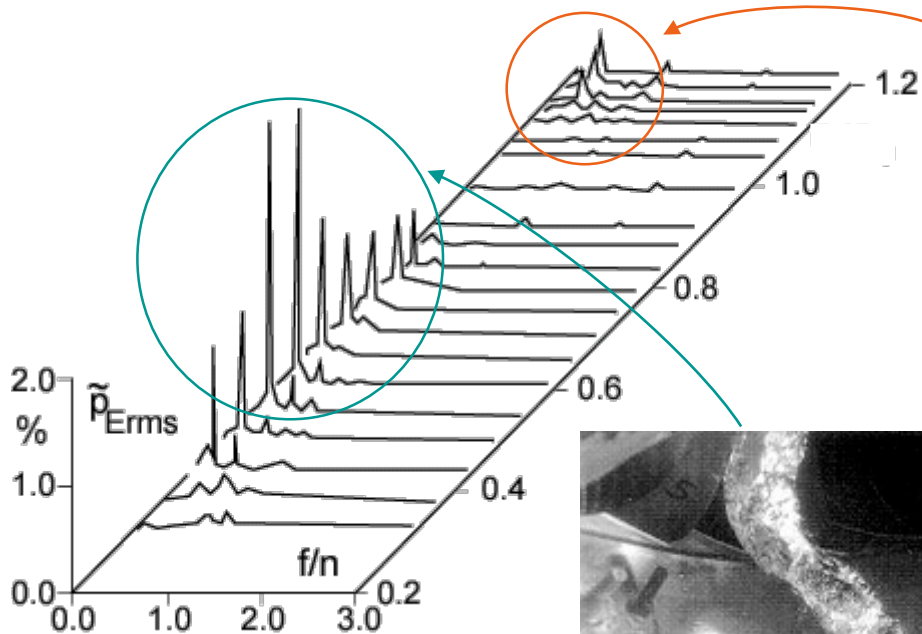

Full Load: $Q > Q_{BEP}$

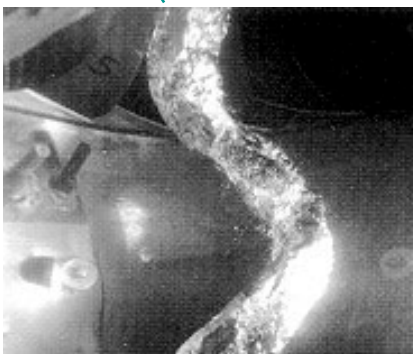

Partial Load: $Q < Q_{BEP}$

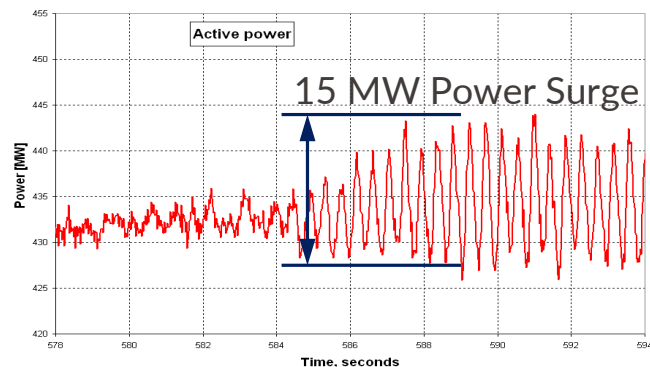

Operating issues

Summary

- Noise, Vibration
- Cavitation Erosion
- Operation Instability
- Performance Alteration
 - Efficiency
 - Characteristic curves

Major Hydroelectric Power Stations are Francis Powered

Hydropower Plant	Country	Capacity (MW)	Energy (TWh)	EPFL Model Testing	Type
Three Gorges	China	22'500	98.5	○	Storage
Itaipú	Brazil-Paraguay	14'000	98.3	✓	Storage
Belo Monte	Brazil	11'233	-	✓	Run-of-River
Guri (Raúl Leoni)	Venezuela	8'850	53.4	✓	Storage
Tucuruí	Brazil	8'370	41.4	✓	Storage
Grand Coulee	USA	6'809	20.0	✓	Storage
Longtan	China	6'426	18.7	○	Storage
Krasnoyarsk	Russia	6'000	20.4	○	Storage
Robert Bourassa (LG2)	Canada	5'616	26.5	✓	Storage
Churchill Falls	Canada	5'428	35.0	○	Storage

Xiangjiaba Power Station (Jinsha River, Yunnan)

- 8 Francis Turbines
- 825 MW Max. Power
- 10.5 m Diameter
- ~ 406 000 kg

Toward 1 GW Unit Capacity?



Classification of Hydraulic Runners

Kaplan Runners

- Kaplan Turbine
 - Reaction machine
 - Axial flow
 - Low head

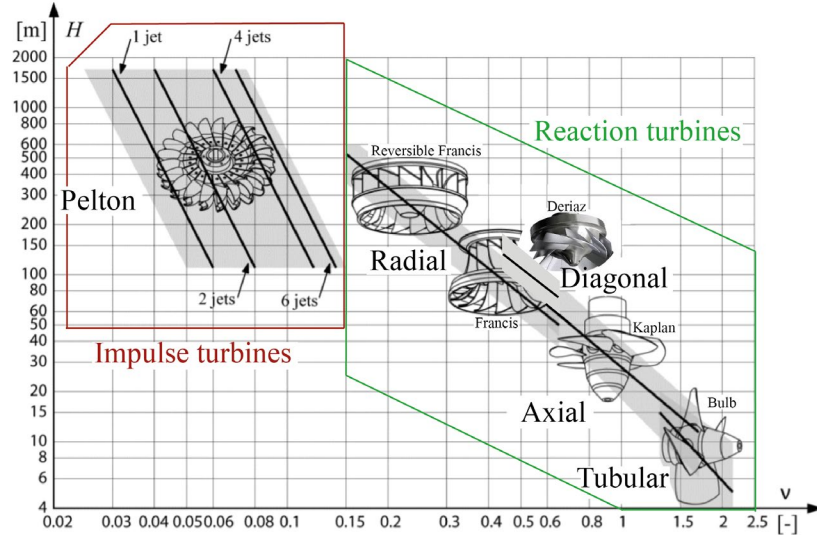

$$n_q = 200 \dots 400$$

$$v = 1.25 \dots 2.50$$

$$n_{QE} = 0.50 \dots 1.20$$

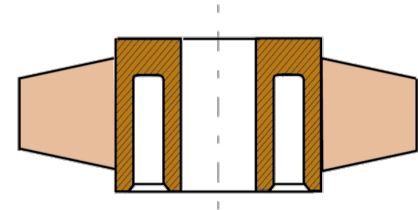

Classification of Hydraulic Runners

Kaplan Runners

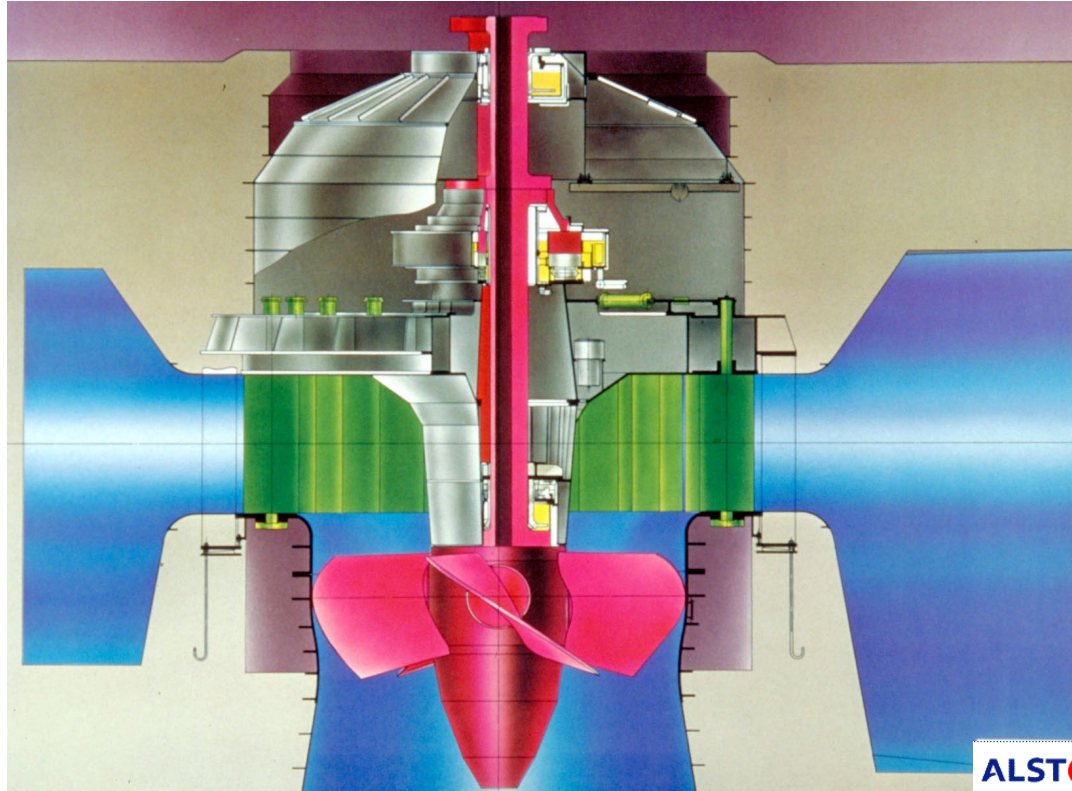

Bulb VS Kaplan

Bulb: fully axial or mixed flow

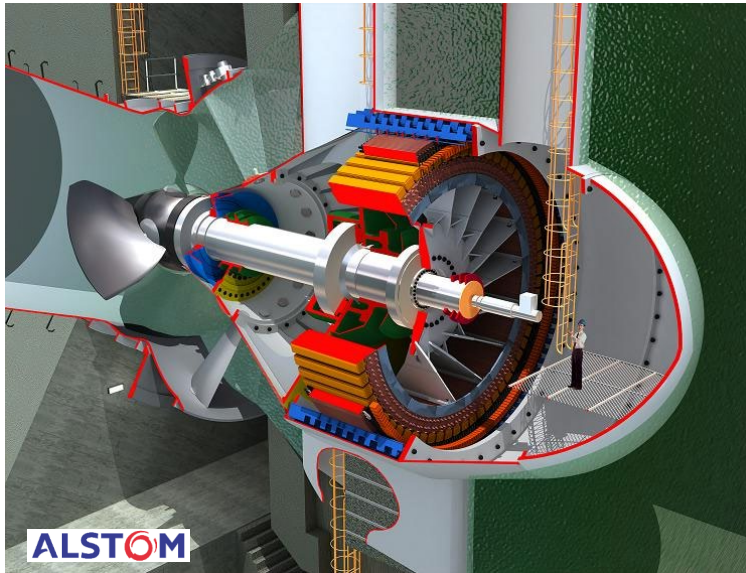

Kaplan: radial guide vanes and axial runner flow

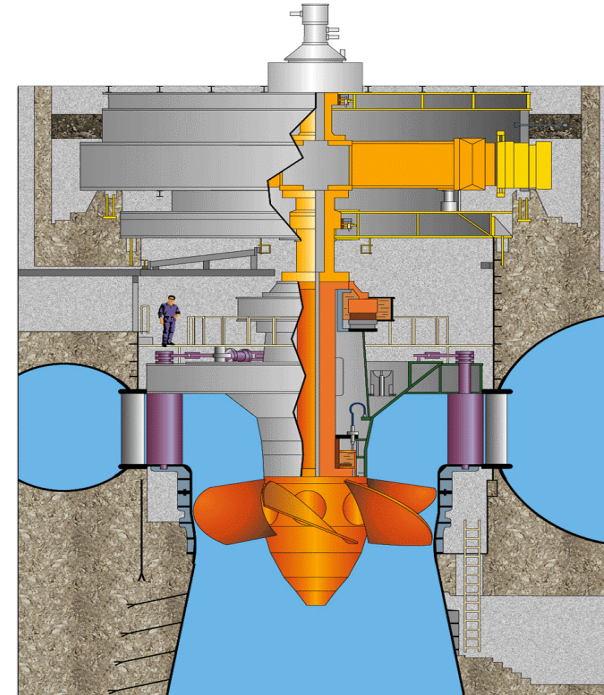

Main Geometrical Data of a Kaplan turbine

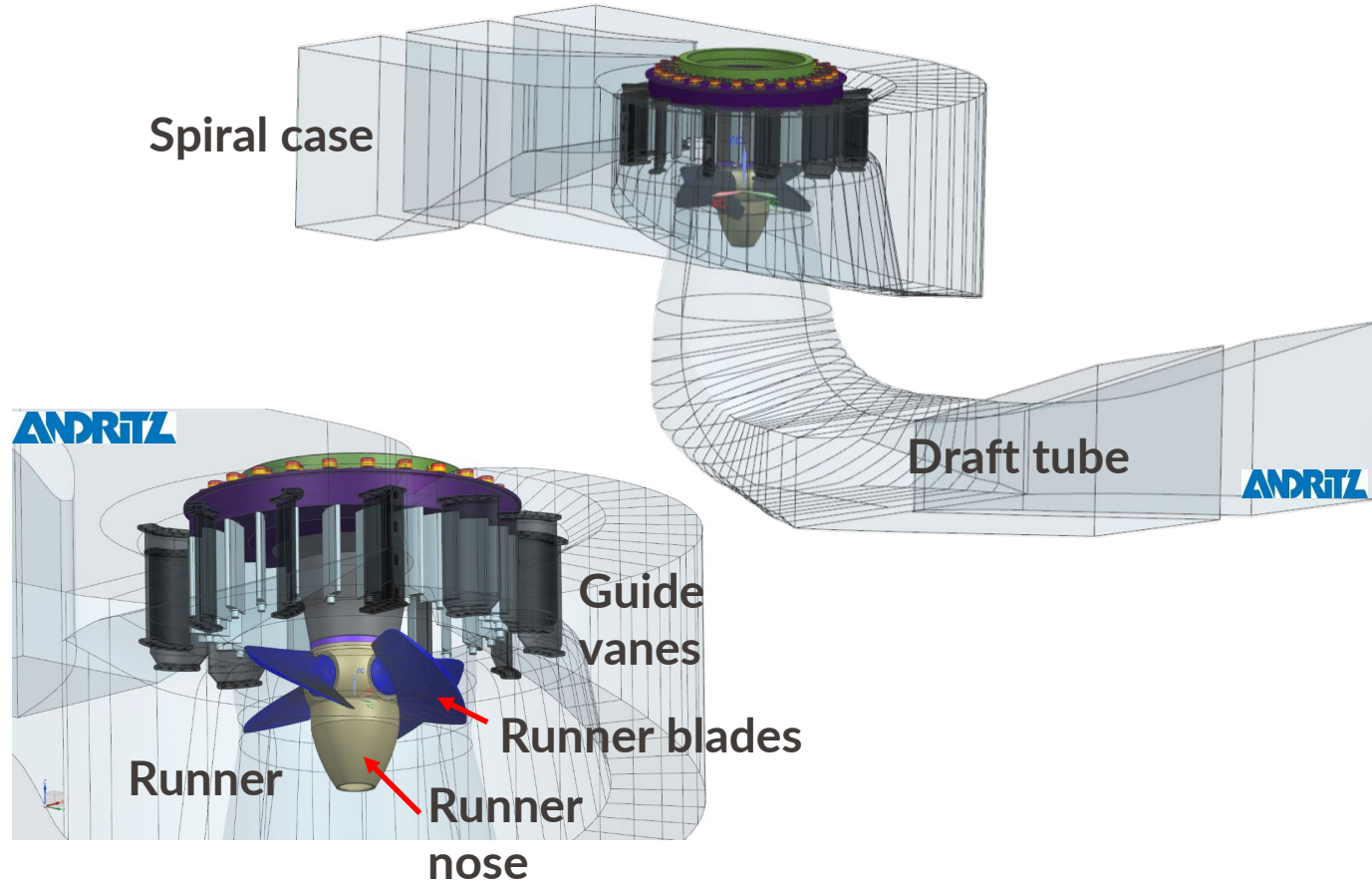

Main Geometrical Data of a Kaplan runner

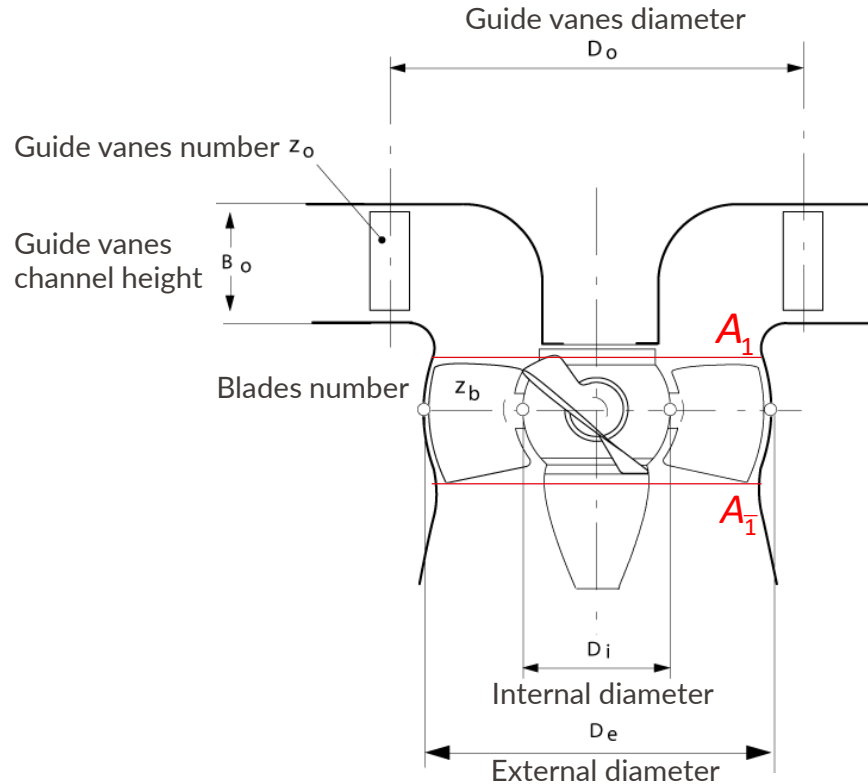

$$A_1 = \pi \frac{D_{1e}^2 - D_{1i}^2}{4}$$

$$A_{\bar{1}} = \pi \frac{D_{\bar{1}e}^2 - D_{\bar{1}i}^2}{4}$$

$$A_1 = A_{\bar{1}}$$

Controllable Pitch Kaplan Runner

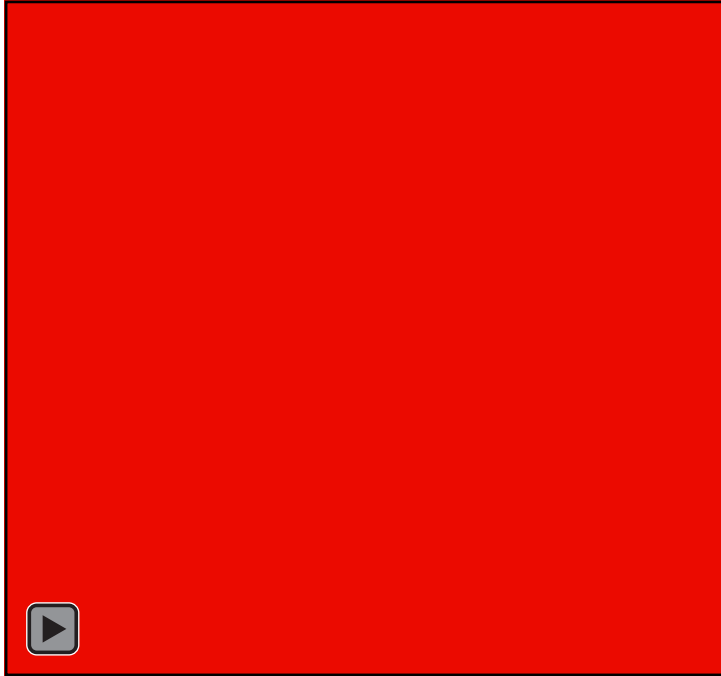

- Blade Base Plates
- Levers
- Connecting Rods
- Piston

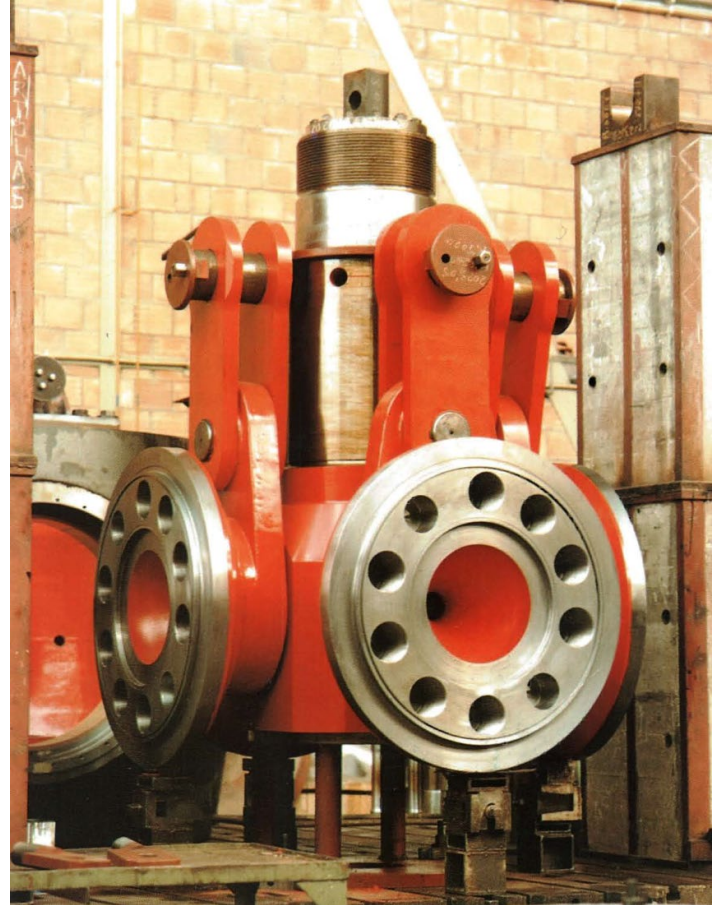

Controllable Pitch Kaplan Runner

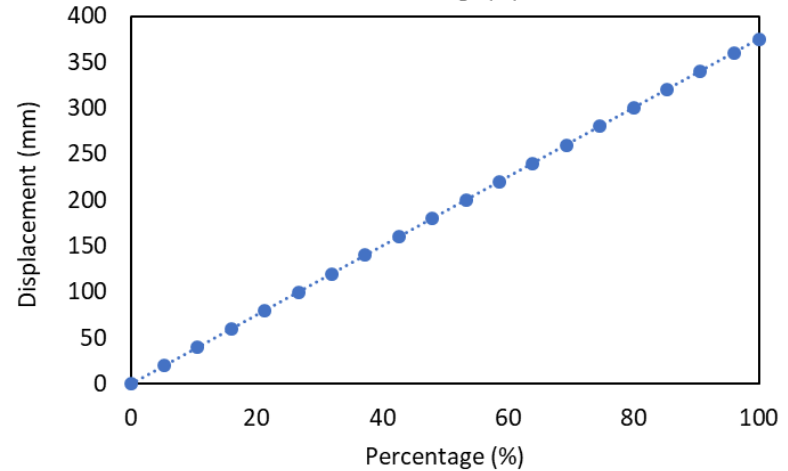
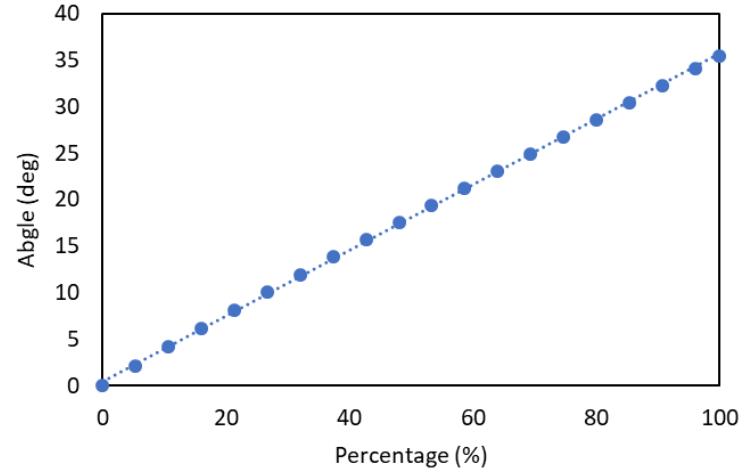
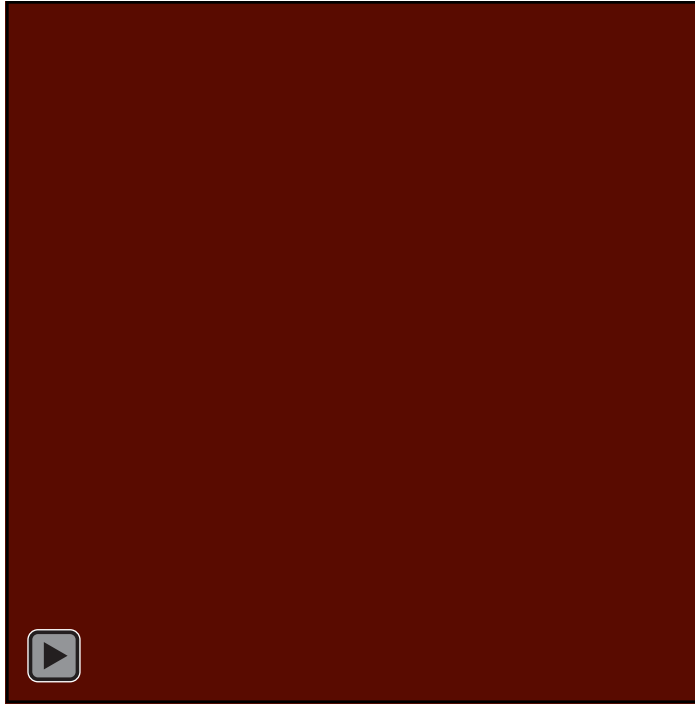

Controllable Pitch Kaplan Runner

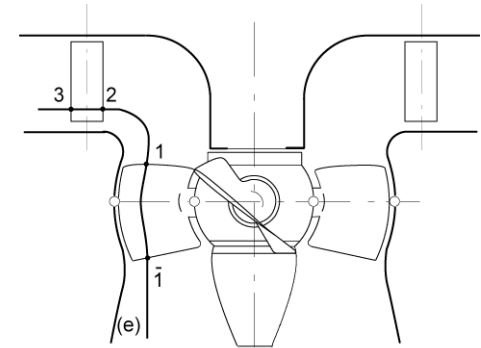
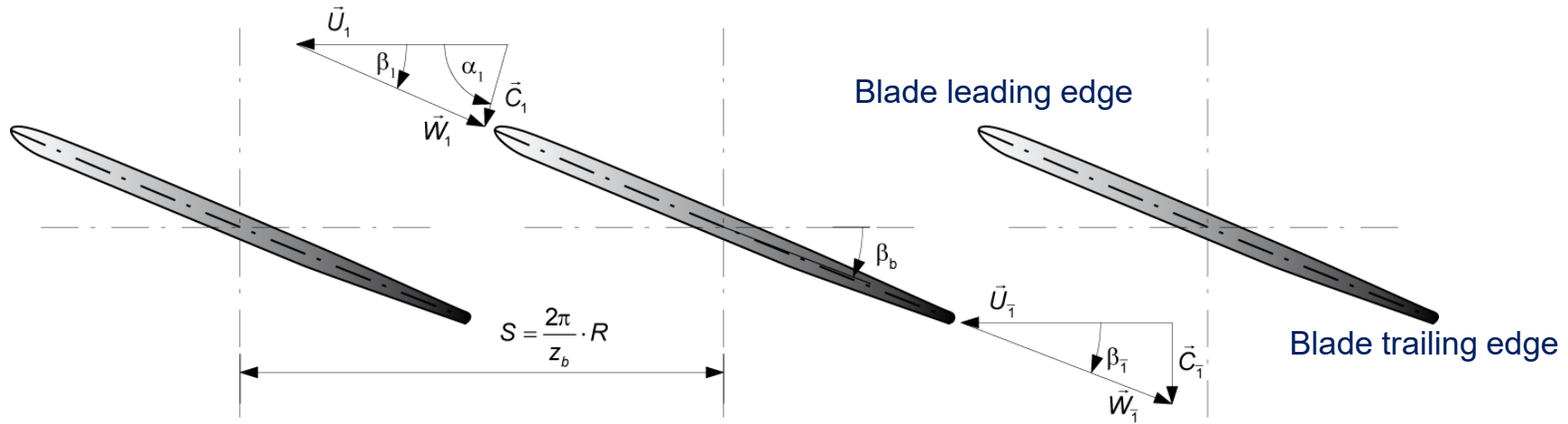

Flow Velocity Diagram

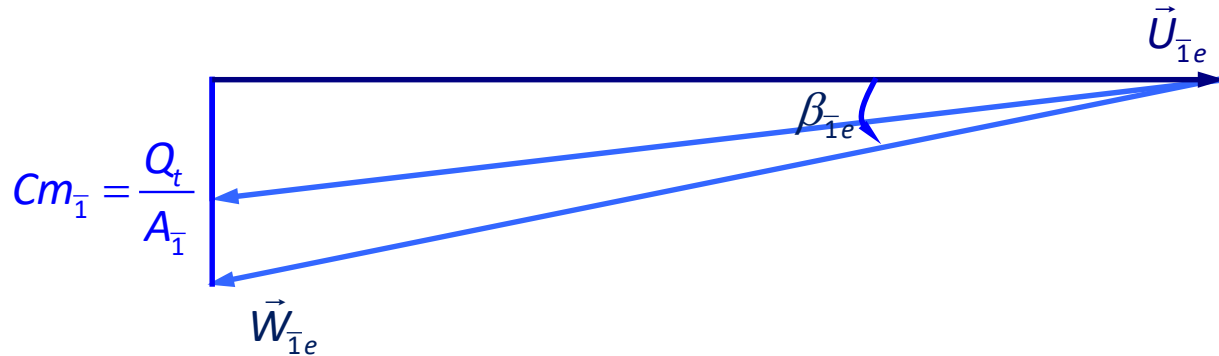
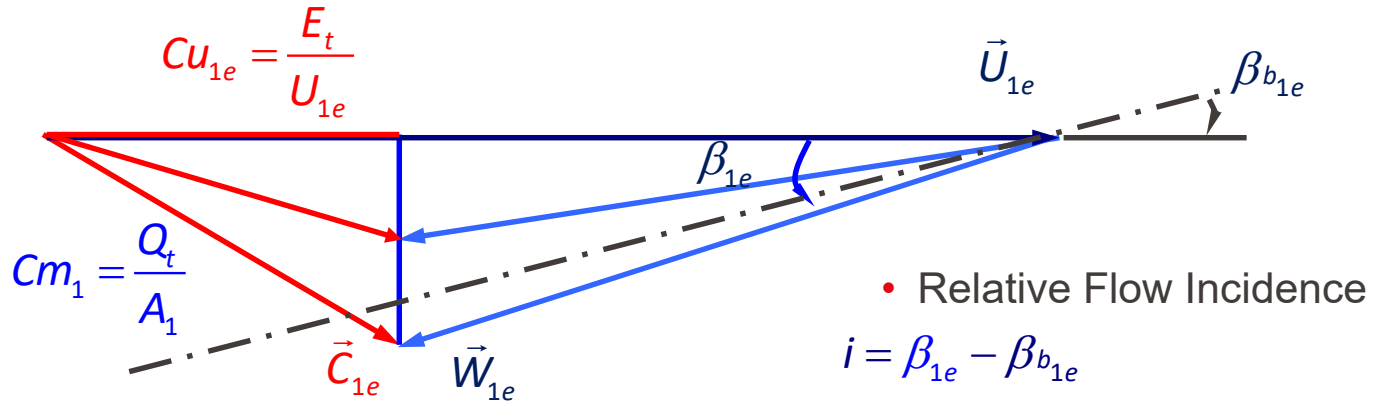

Hydraulic characteristics and on-cam curve

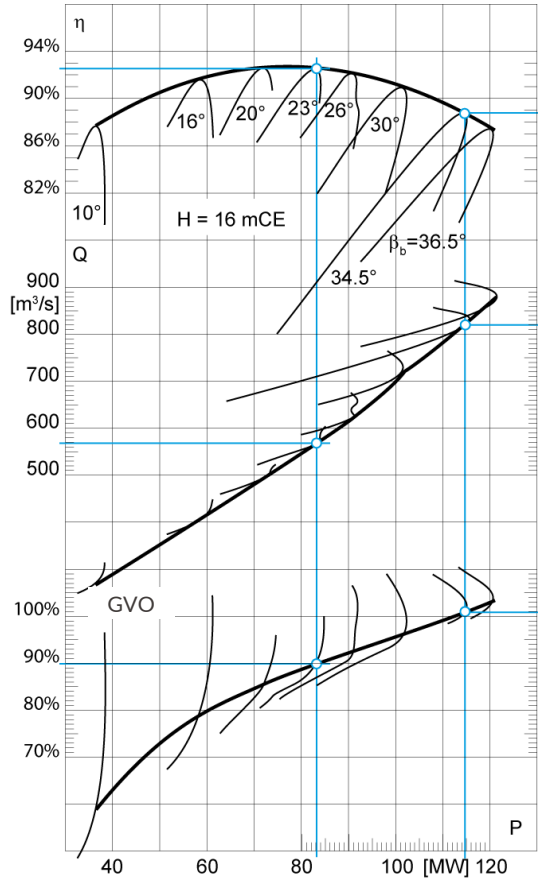

Yacreta Power Plant

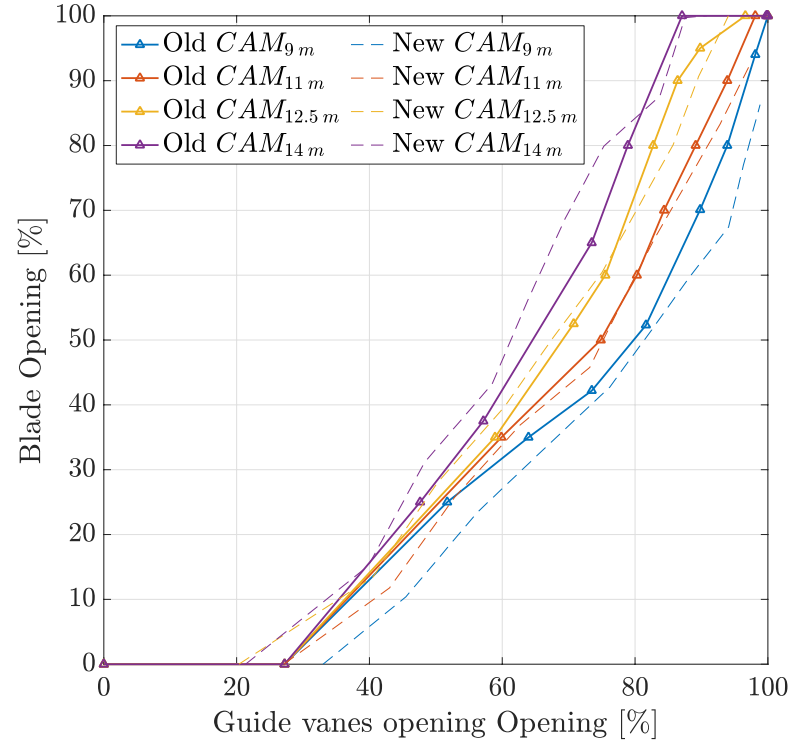

Vogelgrun Power Plant

Kaplan & Bulb Turbines: Main Issues

- Erosion Risk
 - Leading Edge Cavitation
 - Tip Vortex
 - Discharge ring erosion
 - Guide Vane Wakes-Blades interactions
- Efficiency Alteration
 - Hub Cavitation
 - Wear and tear

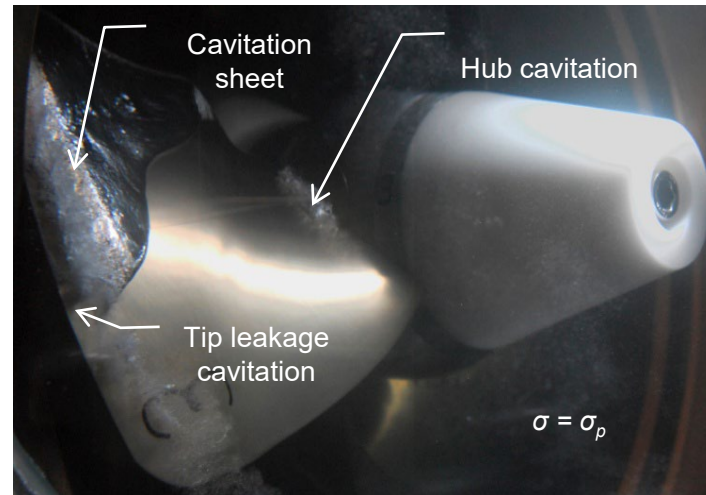

Kaplan Turbine Cavitation mapping

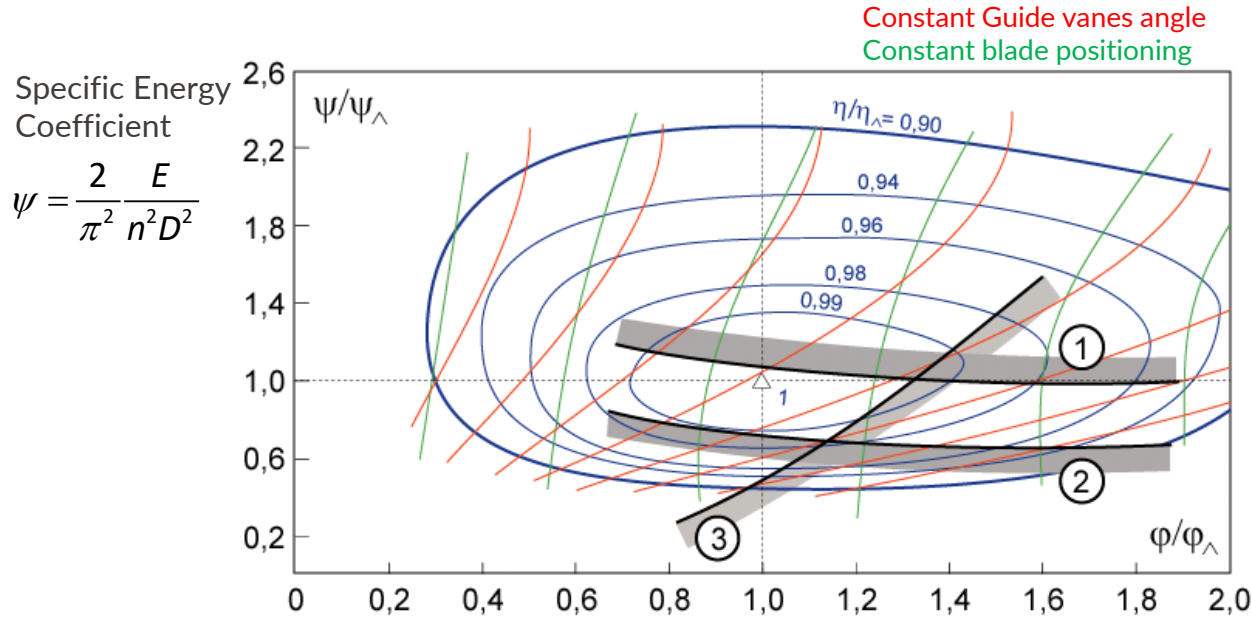

Tip leakage Cavitation



- 1- Leading Edge Suction Side
- 2- Leading Edge Pressure Side
- 3- Hub Cavitation
- Tip leakage Cavitation

Nomenclature:

η_Δ (-) Efficiency at Best Efficiency Point (BEP)

Discharge Coefficient $\phi = \frac{4}{\pi^2} \frac{Q}{nD^3}$

EPFL Wear and Tear

- Fast dynamics (e.g. Frequency containment reserve)
- Number of guide vanes and blades movements
- Mileage

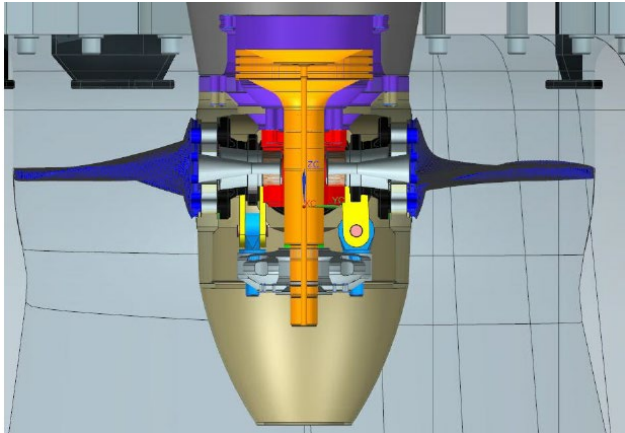

VOGELGRUN , France

- Four vertical Kaplan turbines
 - Battery Hybrid
- $P = 35 \text{ MW}$, $H = 12 \text{ m}$, $Q = 325 \text{ m}^3/\text{s}$

Jirau Hydropower Project (Madeira River)

Energia Sustentável do Brasil S.A.

- Run-of-river hydroelectric station
- 31 km² to 108 km² flooded area
- 83 m to 90 m a.s.l. headwater
- 74 m tailwater level
- 1'150 m long, 62 m high rock filled dam

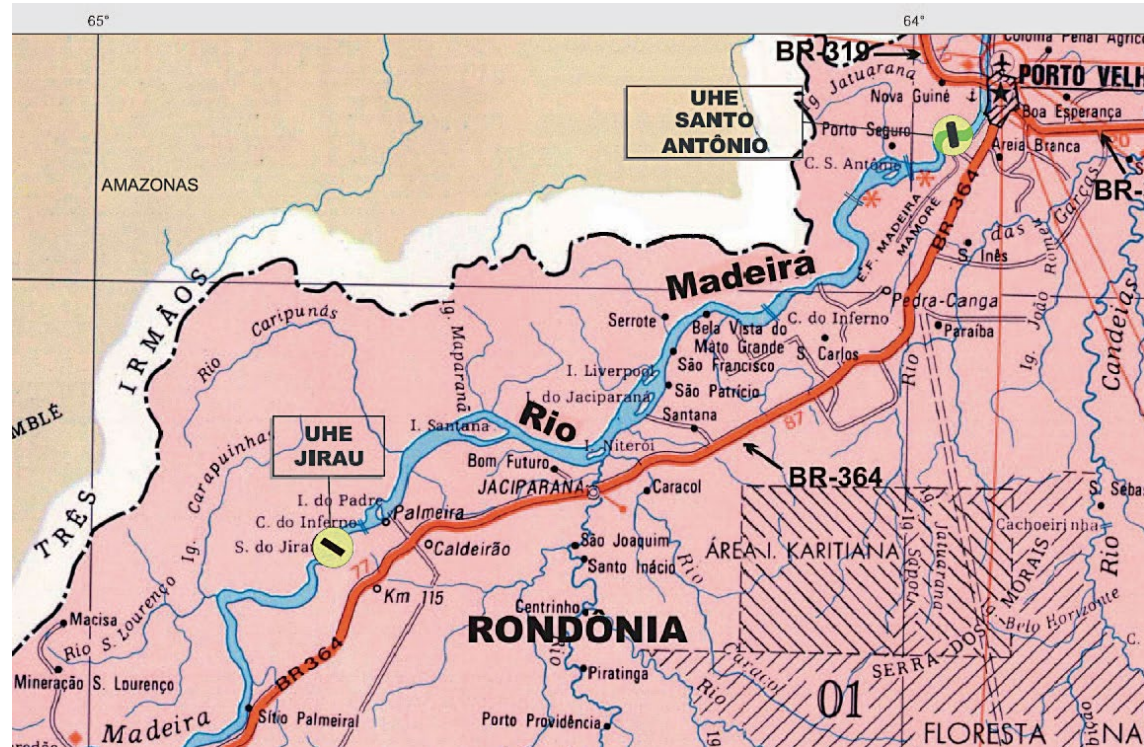

Jirau Hydropower Project (Madeira River) Energia Sustentável do Brasil S.A.



Spillway

18 x 20 m wide radial gates



Jirau, August 30, 2012

Spillway

18 x 20 m wide radial gates



Construction right bank power house



Right Bank Power Station Draft Tube Construction



Right Bank Power Station Draft Tube Construction



Right Bank Power Station Draft Tube Construction



Kaplan Runner and Regulating Ring

